

Surname	Centre Number	Candidate Number
First name(s)		0



**GCSE**

3300U60-1



**WEDNESDAY, 11 NOVEMBER 2020 – MORNING**

**MATHEMATICS  
UNIT 2: CALCULATOR-ALLOWED  
HIGHER TIER**

1 hour 45 minutes

**ADDITIONAL MATERIALS**

A calculator will be required for this examination.  
A ruler, a protractor and a pair of compasses may be required.

**INSTRUCTIONS TO CANDIDATES**

Use black ink or black ball-point pen. Do not use gel pen or correction fluid.  
You may use a pencil for graphs and diagrams only.  
Write your name, centre number and candidate number in the spaces at the top of this page.  
Answer **all** the questions in the spaces provided.  
If you run out of space, use the additional page at the back of the booklet. Question numbers must be given for all work written on the additional page.  
Take  $\pi$  as 3.14 or use the  $\pi$  button on your calculator.

**INFORMATION FOR CANDIDATES**

You should give details of your method of solution when appropriate.  
Unless stated, diagrams are not drawn to scale.  
Scale drawing solutions will not be acceptable where you are asked to calculate.  
The number of marks is given in brackets at the end of each question or part-question.  
In question 2, the assessment will take into account the quality of your linguistic and mathematical organisation, communication and accuracy in writing.

For Examiner's use only		
Question	Maximum Mark	Mark Awarded
1.	4	
2.	7	
3.	4	
4.	2	
5.	4	
6.	5	
7.	2	
8.	3	
9.	4	
10.	6	
11.	2	
12.	3	
13.	6	
14.	2	
15.	3	
16.	3	
17.	4	
18.	3	
19.	5	
20.	8	
<b>Total</b>	<b>80</b>	



NOV203300U60101

### Formula List - Higher Tier

**Area of trapezium** =  $\frac{1}{2}(a + b)h$

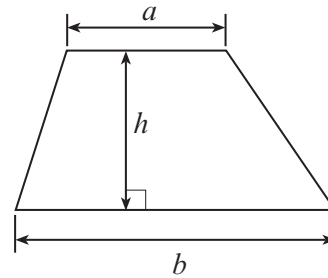

**Volume of prism** = area of cross-section  $\times$  length

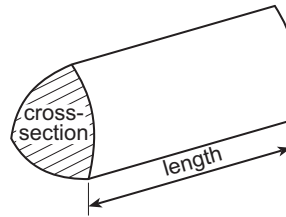

**Volume of sphere** =  $\frac{4}{3}\pi r^3$

**Surface area of sphere** =  $4\pi r^2$

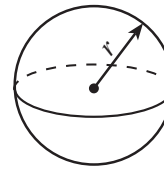

**Volume of cone** =  $\frac{1}{3}\pi r^2 h$

**Curved surface area of cone** =  $\pi r l$

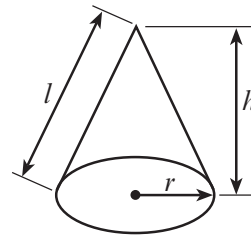

**In any triangle ABC**

**Sine rule**  $\frac{a}{\sin A} = \frac{b}{\sin B} = \frac{c}{\sin C}$

**Cosine rule**  $a^2 = b^2 + c^2 - 2bc \cos A$

**Area of triangle** =  $\frac{1}{2} ab \sin C$

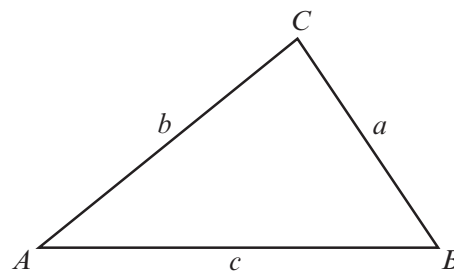

### The Quadratic Equation

The solutions of  $ax^2 + bx + c = 0$  where  $a \neq 0$  are given by  $x = \frac{-b \pm \sqrt{(b^2 - 4ac)}}{2a}$

### Annual Equivalent Rate (AER)

AER, as a decimal, is calculated using the formula  $\left(1 + \frac{i}{n}\right)^n - 1$ , where  $i$  is the nominal interest rate per annum as a decimal and  $n$  is the number of compounding periods per annum.



1. (a) Caryl has two fair dice.

Dice A is a cube. It shows the numbers 1 to 6.

Dice B is a tetrahedron. It shows the numbers 1 to 4.

Caryl throws both dice.

What is the probability that she throws a 5 on dice A and a 3 on dice B?

[2]

.....

.....

.....

.....

.....

- (b) Asif has a biased four-sided dice.  
The dice shows the numbers 10, 20, 30 and 40.

Asif throws the dice once.

The table below gives the probability of obtaining each number.

Number	10	20	30	40
Probability	$\frac{1}{2}$	$\frac{1}{5}$	$\frac{1}{5}$	$\frac{1}{10}$

What is the probability that Asif throws a 30 or a 40?

[2]

.....

.....

.....

.....

.....



2. In this question, you will be assessed on the quality of your organisation, communication and accuracy in writing.

The diagram shows two right-angled triangles, joined together along a common side.  $AB = 10.8$  cm,  $BC = 14.4$  cm and  $CD = 24$  cm.

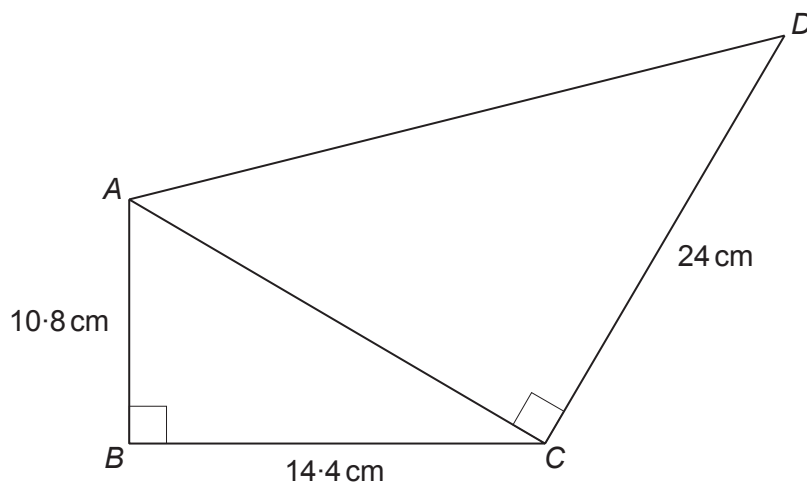

Diagram not drawn to scale

Calculate the area of triangle  $ACD$ .  
You must show all your working.

[5 + 2 OCW]

.....

.....

.....

.....

.....

.....

.....

.....

.....

.....

.....

.....

.....

.....

.....

.....

.....

.....

.....

.....





4. (a) Which one of the following options describes  $2x + 5y$ ?  
Circle your answer. [1]

an equation                      a formula                      an expression

an inequality                      none of these

- (b) Which one of the following options describes  $3x - 2 = 7$ ?  
Circle your answer. [1]

an equation                      a formula                      an expression

an inequality                      none of these

5. Data for different values of  $t$  are shown in the table below.

$t$	Frequency
$0 \leq t < 5$	8
$5 \leq t < 10$	0
$10 \leq t < 15$	7
$15 \leq t < 20$	5

Calculate an estimate for the mean value of  $t$ . [4]

.....

.....

.....

.....

.....

.....

.....

.....

.....



6. In the diagram below,  $AB$ ,  $BC$  and  $CD$  are three sides of a **regular polygon**.  
The polygon has 15 sides.  
The length of each side is 8 cm.

The exterior angle of the polygon is  $x^\circ$ .  
 $BRC$  is a right-angled triangle.

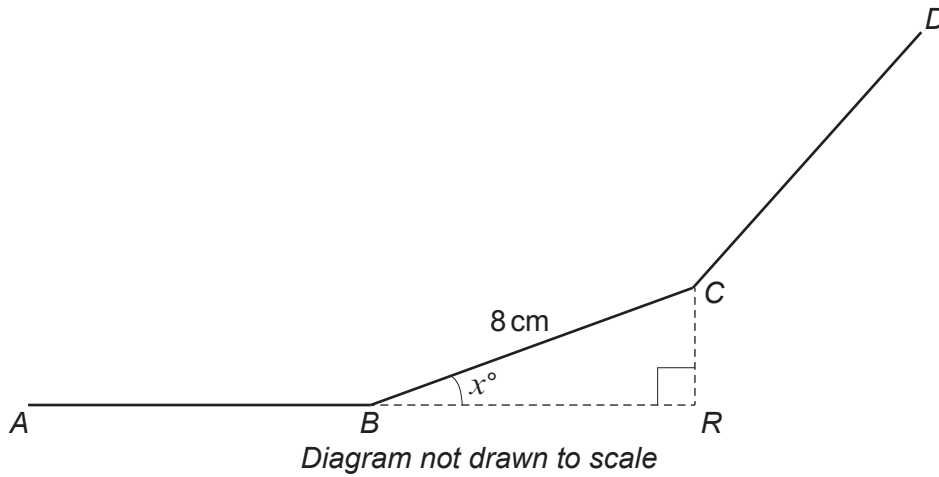

Calculate the length of  $BR$ .

[5]

.....

.....

.....

.....

.....

.....

.....

.....

.....

.....

.....

.....

.....

.....

.....

.....

.....

.....

.....

.....

.....

.....

.....



7. Calculate the value of  $(3.2 \times 10^7) \times (8.3 \times 10^{-2})$ .  
Give your answer in standard form.

[2]

.....

.....

.....

.....

8. The lengths of the sides of a rectangle are given as 24 cm and 15 cm.  
Each measurement is given correct to the nearest centimetre.

Calculate the difference between the greatest possible perimeter of the rectangle and the least possible perimeter of the rectangle. [3]

.....

.....

.....

.....

.....

.....

.....

.....

.....

.....

.....

.....

.....

.....

.....

.....

.....

.....

.....

.....

.....

.....





9. Solve the following simultaneous equations using an algebraic (not graphical) method.

$$\begin{aligned}3x - 2y &= 14 \\7x + 3y &= 25\end{aligned}$$

You **must** show all your working.

[4]

.....

.....

.....

.....

.....

.....

.....

.....

.....

.....

.....

.....

.....

.....

.....

.....

.....

.....

.....

.....

.....

.....

.....

.....



10. The diagram below shows a circle with centre at point  $O$ .  
 $A$ ,  $B$ ,  $C$  and  $D$  are all points on the circumference of the circle.  
 $AB = 7.5$  cm and  $BC = 4.7$  cm.

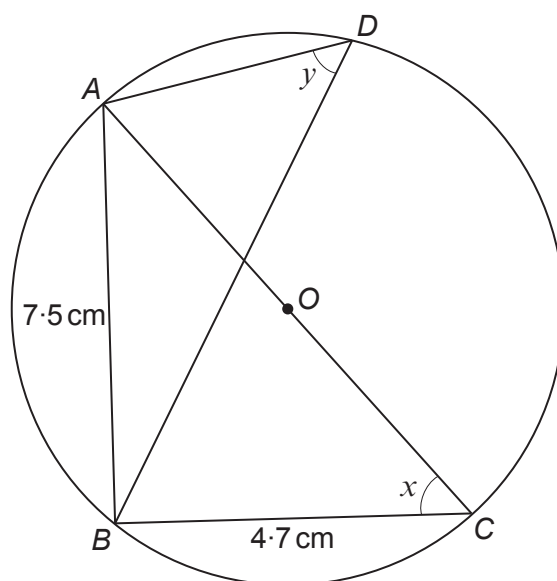

Diagram not drawn to scale

- (a) (i) Give the reason why  $\hat{ABC}$  is  $90^\circ$ . [1]

.....

.....

- (ii) Calculate the size of angle  $x$ . [3]

.....

.....

.....

.....

.....

.....

- (b) Write down the size of angle  $y$ .  
 State the circle theorem you have used to find your answer. [2]

$y =$  .....

Circle theorem used: .....

.....



11. Write  $16^{100}$  in the form  $2^n$ .

[2]

.....

.....

.....

.....

.....

.....

12. Calculate the perpendicular height of a cone with a volume of  $5533\text{ cm}^3$  and a base area of  $825\text{ cm}^2$ .

[3]

.....

.....

.....

.....

.....

.....



13. (a) Factorise  $4x^2 - 81$ .

[2]

.....

.....

.....

.....

.....

.....

(b) Factorise  $7x^2 + 10x - 8$ .

[2]

.....

.....

.....

.....

.....

.....

(c) Factorise  $(x + 2)^3 + 5(x + 2)^2$ .

[2]

.....

.....

.....

.....

.....

.....

.....

.....

.....

.....



14. In the following diagram, triangle  $ABC$  has been enlarged to triangle  $DEF$ , with the centre of enlargement at  $O$ .  
Write down the scale factor of the enlargement. [2]

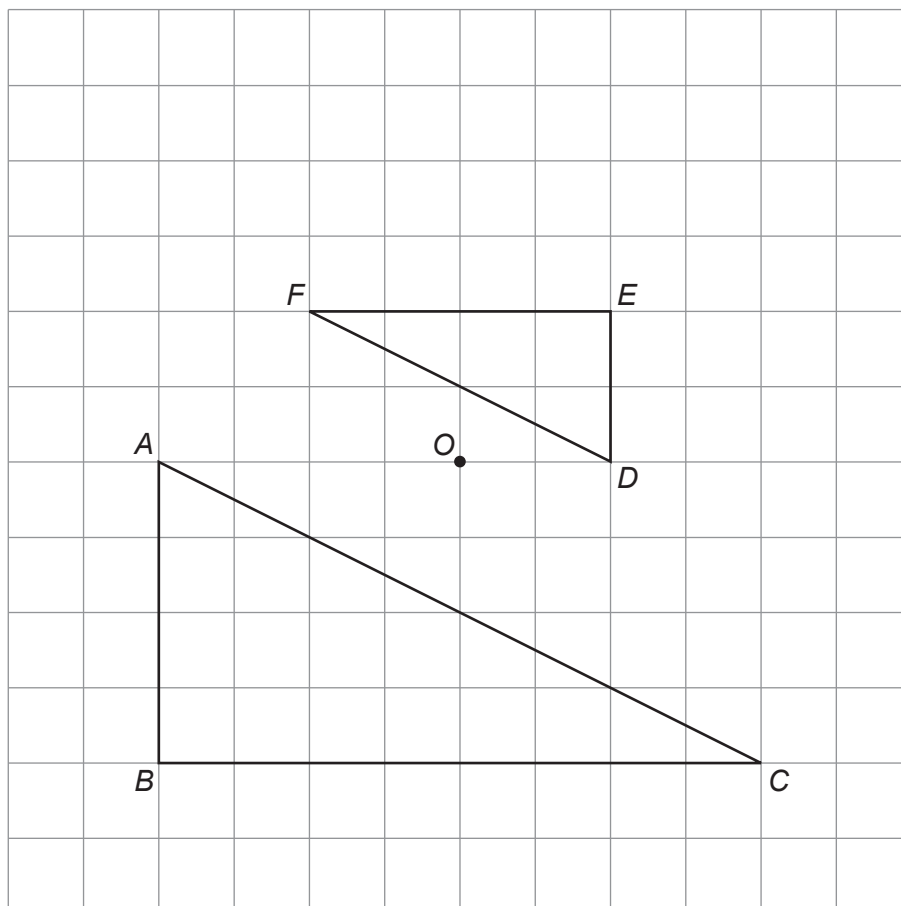

Scale factor: .....



15. The first four terms of a sequence are

3,      9,      19,      33,      .....

Find the 100th term of the sequence.

[3]

.....

.....

.....

.....

.....

.....

.....

.....

.....

.....

.....

.....

.....



16. An amount written correct to the nearest £10 is £7180.  
This amount is increased by 23.5%, correct to the nearest 0.1%.  
Calculate the **least** possible value of the increased amount.  
Give your answer correct to the nearest pound.

[3]

.....

.....

.....

.....

.....

.....

.....

.....

.....

.....



17. (a) Sketch the curve  $y = \cos x$ , for values of  $x$  in the range  $x = 0^\circ$  to  $x = 360^\circ$ .  
You must indicate any important values on the axes.

[2]



- (b) Solve the equation  $\cos x = 0.7$ .  
Give all solutions in the range  $x = 0^\circ$  to  $x = 360^\circ$ .

[2]

.....

.....

.....

.....

.....

.....

.....

.....

.....

.....

.....

.....

.....

.....

.....

.....

.....

.....

.....

.....

.....

.....





18. A large number of people took part in a survey that was carried out to find the popularity of three different walks in West Wales. Each person surveyed was asked, independently, to select their one favourite walk. The table below shows the results of the survey.

Walk	The percentage of people who selected the walk
The Preseli Ridge	70%
Ramsey Sound	20%
Laugharne	10%

Three girls, Constance, Scarlett and Clementine, were chosen at random from all of the people surveyed.

They were asked which walk they had selected.

Calculate the probability that the three girls had each selected a different walk. [3]

.....

.....

.....

.....

.....

.....

.....

.....

.....



19. Use the quadratic formula to solve  $(5x + 3)(5x - 3) = 19x$ .  
Give your answers correct to 2 decimal places.  
You must show all your working.

[5]

.....

.....

.....

.....

.....

.....

.....

.....

.....

.....

.....

.....

.....

.....

.....

.....

.....

.....

.....

.....

.....

.....

.....

.....

.....

.....



20.  $ACB$  is a sector of a circle with radius  $x$  cm and centre  $A$ , as shown below.

$\hat{CEA} = 34^\circ$ ,  $\hat{ACE} = 100^\circ$ ,  $\hat{CAE} = 46^\circ$  and  $CE = 12$  cm.

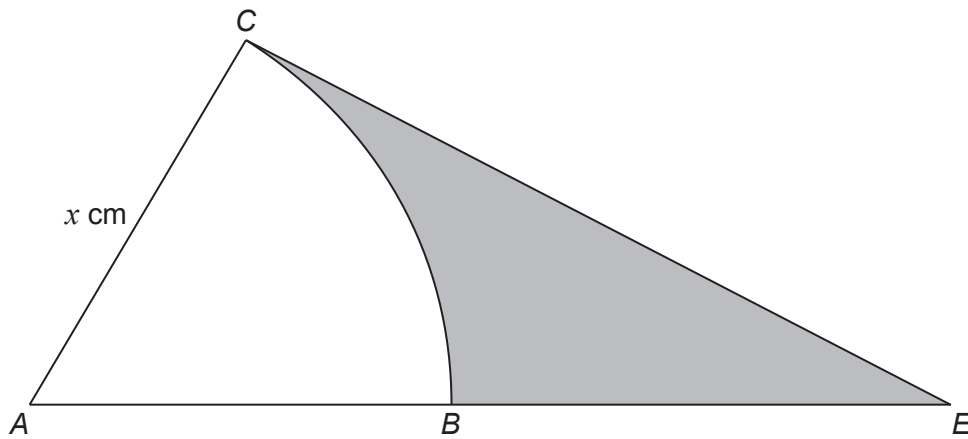

*Diagram not drawn to scale*

Calculate the area of the shaded region  $BCE$ .  
You must show all your working.

[8]

.....

.....

.....

.....

.....

.....

.....

.....

.....

.....

.....

.....

.....

.....

.....

.....

.....

.....

.....

.....

.....

.....

.....



